



# Blacksmith Stoves®



*Multi Fuel  
Heating Solutions for Every Home*

*'A Cast Iron Masterpiece'*





# WHY CHOOSE A BLACKSMITH STOVE?

The initial question one should always ask is why choose a stove in the first place. Are they not expensive and difficult to install?

Did you know that a staggering 70% of the heat generated from an average open fire can escape up the chimney! Modern stoves burn so efficiently that less than 20% of your heat escapes, thereby reducing fuel costs and harmful emissions. A Blacksmith stove will pay for itself very quickly considering the reduced fuel usage and the increased radiant heat output to your home. With regard to installation, whether you want a stand alone heat source or to heat your water and radiators, stove installation is fast and easy.

So why choose a Blacksmith stove? Buying a stove is an investment and if you want to be assured of the very best quality and safety, expert advice, cutting edge stove technology, great design and a super after sales service then the brand of choice is Blacksmith.

The Blacksmith team recognised from the start that stoves would be a desirable heating solution in both contemporary and traditional homes. Our designers made sure that Blacksmith stoves look as good in urban townhouse settings as they do in a country farmhouse or rural cottage.

The durable cast iron construction ensures a long lasting, low maintenance stove that will give years of trouble free heat to your home. All our stoves are suitable for "Overnight Burning" giving a warm home on those cold winter mornings. The polished stainless steel fittings are guaranteed not to rust or peel.

These multi-fuel stoves will burn all types of commercially approved solid fuels such as coal, wood, peat, turf, briquettes and anthracite.

We would agree that many stoves look good on the outside, but what is on the inside? All Blacksmith stoves are fitted with heat resistant "17.8% Certified High Chrome" internal castings which not only makes the stoves suitable for burning smokeless fuels (Smokeless fuels burn at higher temperatures than normal household coal.), but also prolongs the lifetime of the grate. Not all stoves can make this claim. All Blacksmith Stoves have received the internationally recognized and coveted German Amtliche Materialprüfungsanstalt seal of approval.

Blacksmith Stoves are CE approved and meet DIN EN 13240 standards.

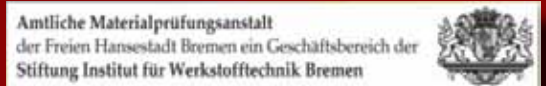

We are aware that Blacksmith Stoves may not be the cheapest available, but we are happy to say that they represent the best in value; a quality that cannot be measured solely on price.

A Blacksmith Stove is a stove for life and we are happy to stand over each and every one. Besides, thousands of happy, warm and snug Irish homeowners are happily standing over (or perhaps sitting beside) their beautiful Blacksmith stoves right now.

Blacksmith Stoves, 'A Cast Iron Masterpiece' at the heart of warm homes.



# The Anvil

## Technical Specification

### Output:

Non-Boiler model 6 KW (21,000 BTU)

Boiler model 4 KW (14,000 BTU)  
(DHW) to room  
2 KW (7,000 BTU)  
to water

Efficiency: Up to 80%

Dimensions: See page 8

Weight: ca 79 KG

Flue Diameter: 125mm (5") Nominal  
Flue outlet top or back

### Additional Features:

- Primary and Secondary air controls
- Air wash for clean glass
- Cleanburn technology
- Suitable for overnight burning
- Certified High Chrome internal castings



## The Anvil

The Anvil is the smallest Blacksmith multi fuel stove yet has an impressive radiant heat output for its compact size. Beautifully made in cast iron, the Anvil is available in matt black and enamel finishes. It comes in non boiler and boiler format, allowing it to heat a domestic hot water cylinder and in some cases will also run 1-2 small radiators.

Neat and elegant in design the Anvil complements a contemporary or traditional interior. With a clear view of the flames through the generously sized front glass, the presence of an Anvil creates a warm and welcoming focal point in any room.

For long lasting warmth and value combined with tidy elegance, the Anvil is the perfect choice of Blacksmith stove.



Brown Enamel Non Boiler Only



Black Enamel



Black Matt

# The Artisan *Convection and Radiant Multi Fuel Insert*

## Technical Specification

### Output:

Non-Boiler model 5KW (17,000 BTU)

Boiler model 4 KW (14,000BTU)  
to room  
8 KW (27,000 BTU)  
to water  
Heats 7-8 Radiators

Efficiency: Up to 75%

Dimensions: See page 8

Weight: ca 109 Kgs. Boiler model  
ca 91 Kgs. Non-Boiler model

Flue Diameter: 150mm (6") Nominal -  
Top outlet only

### Additional Features:

- Fits standard 16" and 18" fireplaces without removing fireback
- Primary and Secondary air controls
- Convection and Radiant heat
- Improves home energy rating (BER)
- Air wash for clean glass
- Environmentally friendly due to Cleanburn Technology
- Suitable for overnight burning
- Certified High Chrome internal castings
- Cast Iron internal back and side bricks
- Large glass door
- Easy installation



## *The Artisan*

The Artisan insert stove is the cosy solution when you want to retain the look of your fireplace but crave the efficiency of a stove. With the beautiful cast iron Artisan insert you retain all the benefits of an open fire with the advantages of reduced fuel usage and less draughts.

It is easy to install and less fuel means reduced fuel costs; kind to your pocket and the environment.

The Artisan insert stove from Blacksmith, the elegant and cost effective way to your very own cast iron masterpiece.



Black Enamel

Black Matt

# The Bellows

## Technical Specification

### Output:

Boiler model 5 KW (17,000 BTU)  
to room  
6 KW (20,000 BTU)  
to water  
Heats 5 - 6 Radiators

Non-Boiler model 8 KW (27,000 BTU)

Efficiency: Up to 79%

Dimensions: See page 9

Weight: ca 120 KG

Flue Diameter: 150mm (6") Nominal  
Flue outlet top or back

### Additional Features:

- Primary and Secondary air controls
- Air wash for clean glass
- Cleanburn technology
- Suitable for overnight burning
- Certified High Chrome internal castings



## The Bellows

The Bellows is a medium size stove combining the latest technology with inviting good looks. Skillfully made in cast iron, it comes in striking matt black or enamel finishes. The Bellows non boiler can be enjoyed as a stand alone 8 KW heat source. The Bellows 11 KW boiler model will comfortably heat a water cylinder and 5 to 6 radiators, together with a very generous 5 KW of radiant heat to the room.



Brown Enamel



Black Enamel



Black Matt

Through the large glass door enjoy the sight of rich flames, the strength of which can be manually controlled.

A beautiful stove to treasure, the Bellows is considered a jewel in the Blacksmith range.

# The Forge

## Technical Specification

### Output:

Non-Boiler model 16 KW (55,000 BTU)

Boiler model 8 KW (27,000 BTU)  
to room  
12 KW (40,000 BTU)  
to water  
Heats 8 – 12 Radiators

Efficiency: Up to 73%

Dimensions: See page 10

Weight: ca 200 KG

Flue Diameter: 150mm (6") Nominal  
Flue outlet top or back

### Additional Features:

- Primary and Secondary air controls
- Thermostatic control of water temperature
- Air wash for clean glass
- Cleanburn technology
- Suitable for overnight burning
- Certified High Chrome internal castings



## The Forge

The Forge has strength and power hidden behind its sleek and stylish appearance. Available in matt black or enamel finish it can also heat up to twelve radiators, supply ample hot water and run a domestic home heating system while generously emitting heat to your room. The water temperature is controlled by a mechanical thermostat.

As a stand alone heat source it is the ultimate choice in natural home heating, with the visible flames and radiant heat warmly transforming large rooms and open plan spaces.

Well designed and graceful in appearance, in the flames of the Forge, Blacksmith glows with pride.



Brown Enamel Boiler Only



Black Enamel



Black Matt

# The Farrier



## Technical Specification

Output:

Non-Boiler model 23 KW (78,000 BTU)

Boiler model 8 KW (27,000 BTU)  
to room  
15 KW (51,000 BTU)  
to water  
Heats up to 14 radiators

Efficiency: Up to 77%

Dimensions: See page 9

Weight: ca 226 KG

Flue Diameter: 150mm (6") Nominal  
Flue outlet top or back

## Additional Features:

- Primary and Secondary air controls
- Thermostatic control of water temperature
- Air wash for clean glass
- Cleanburn technology
- Suitable for overnight burning
- Certified High Chrome internal castings



## *The Farrier*

The Farrier is a statement stove. The double door design allows it to service the largest of homes and yet its simplicity of use makes it an attractive option.

The generous opening on this multi fuel stove allows for large logs and the thermostatic control ensures fuel efficiency, burning only what is needed for the level of heat required. The Farrier can be a single source of home heating or an integral part of your water and radiator heating system, while retaining the benefits of a visible flame and the warmth of a real fire.

For the best of both worlds; a cosy, inviting home and a real open fire flame, the Farrier stove from Blacksmith is a true cast iron masterpiece.



Black Enamel

Black Matt

# The Furnace 30 KW

## Technical Specification

Output:	8 KW (27,000 BTU) to room 22 KW (75,000 BTU) to water Heats up to 20 radiators
Efficiency:	Up to 75%
Dimensions:	See page 10
Weight:	ca 265 KG
Flue Diameter:	150mm (6") Nominal Top outlet only

## Additional Features:

- Primary and Secondary air controls
- Thermostatic control of water temperature
- Air wash for clean glass
- Environmentally friendly due to Cleanburn Technology
- Suitable for overnight burning
- Certified High Chrome internal castings



## *The Furnace* (BOILER MODEL AND TOP OUTLET ONLY)

The Blacksmith Furnace, as the name suggests, is a double door powerhouse of a stove that has been created for the extra large home.

Designed to fit in with both contemporary and traditional interiors, the Furnace certainly makes the grade when it comes to appearance. Its heating ability is second to none and will easily provide central heating, domestic hot water and become a warm radiant focal point in any room.

The Furnace multi fuel stove is the ultimate choice for creating warm and snug spaces in generously proportioned homes.



Black Matt



# The Anvil

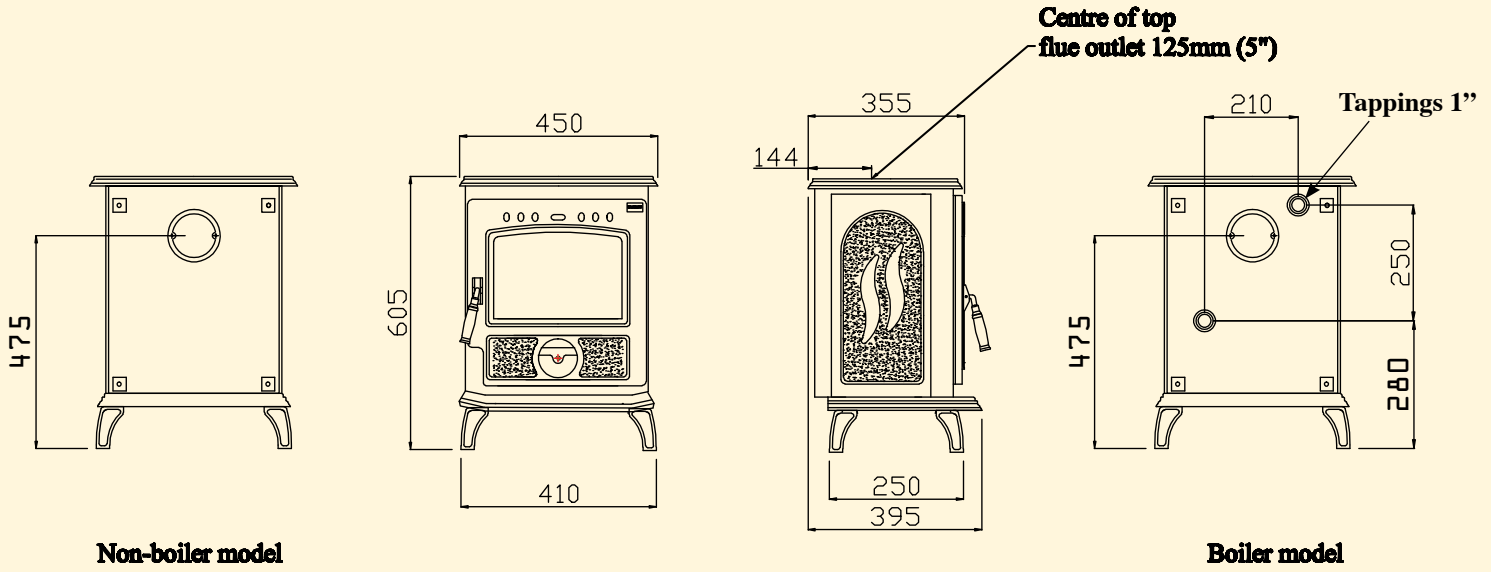

Legs adjustable for levelling (shorter & longer legs available)

# The Artisan

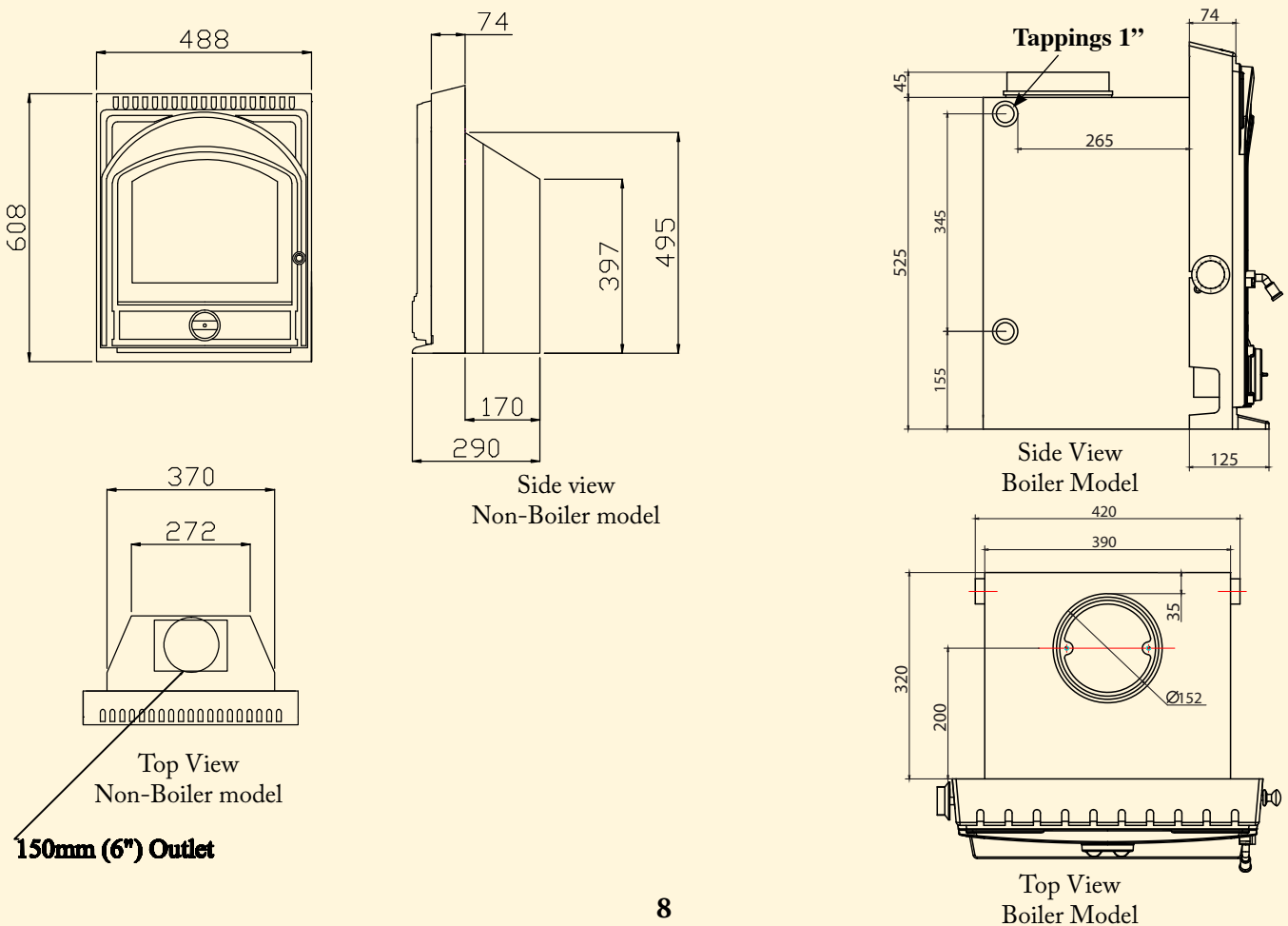

# The Bellows

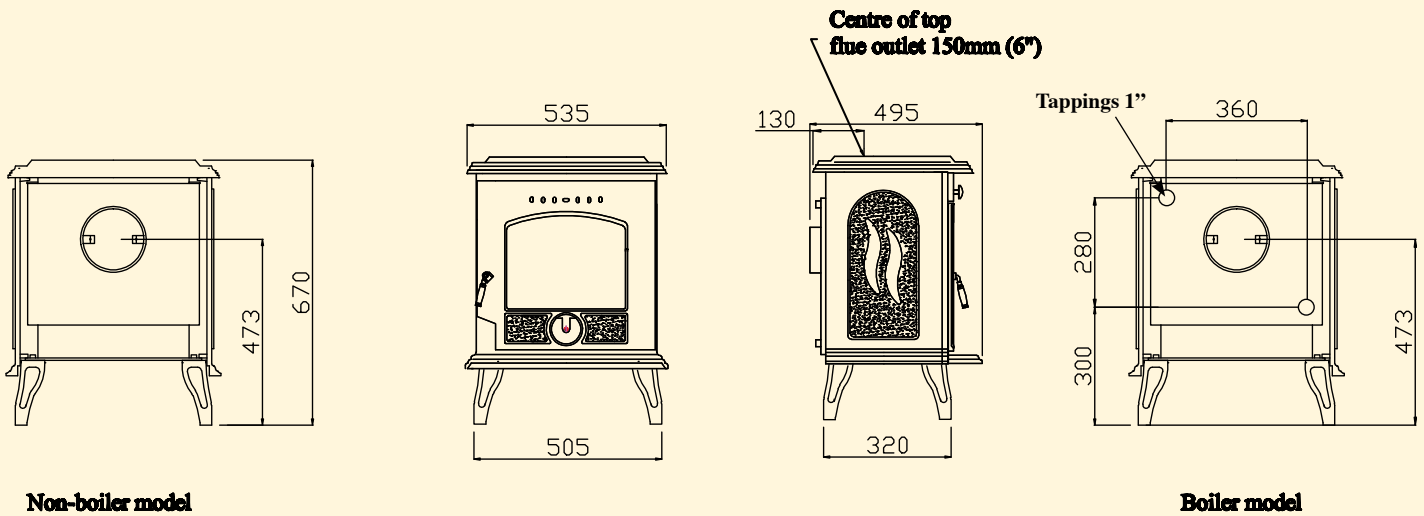

Legs adjustable for levelling

# The Forge

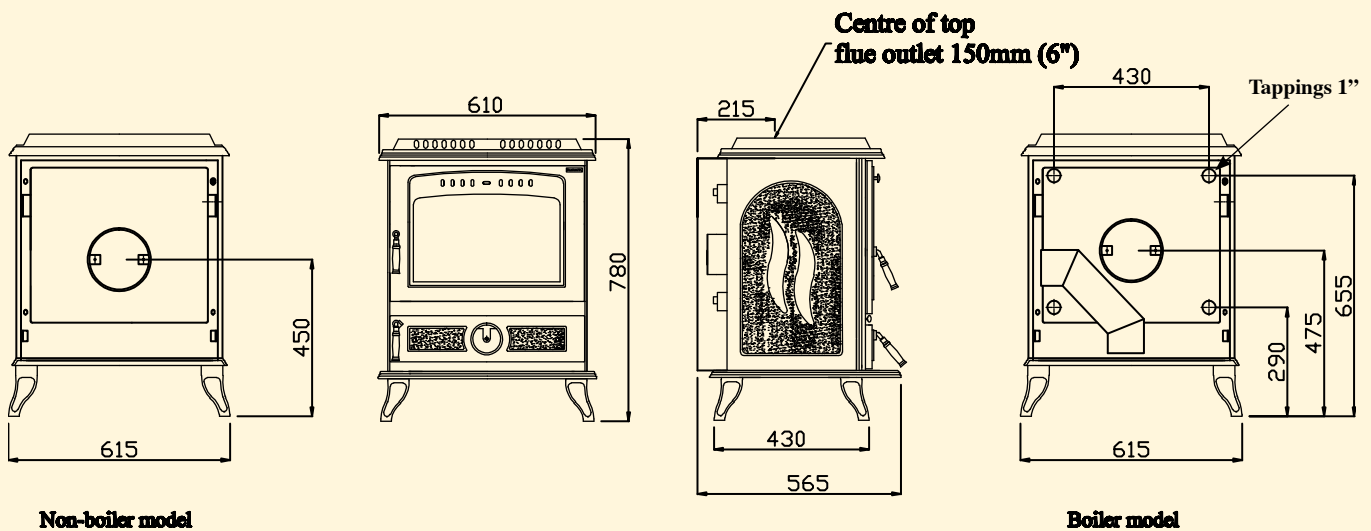

Legs adjustable for levelling

# The Farrier

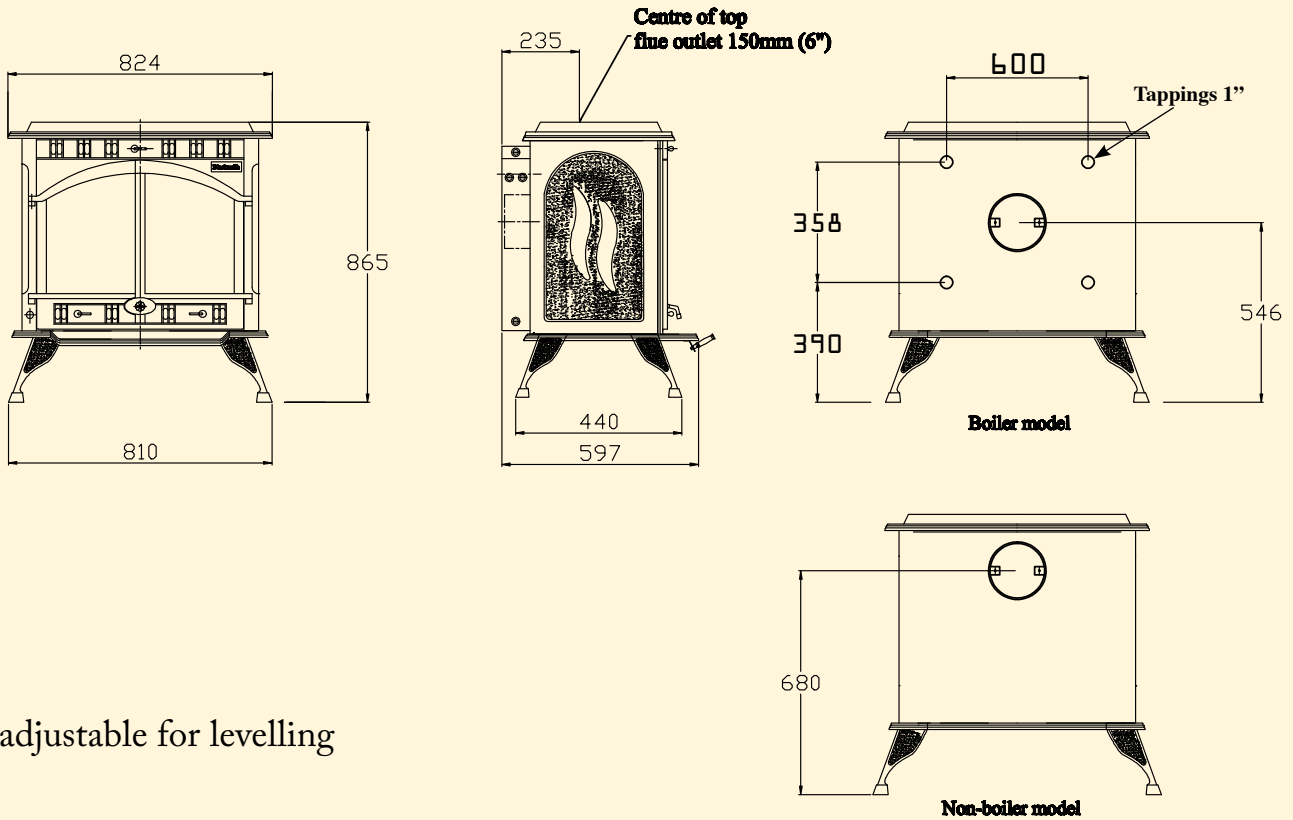

Legs adjustable for levelling

# The Furnace

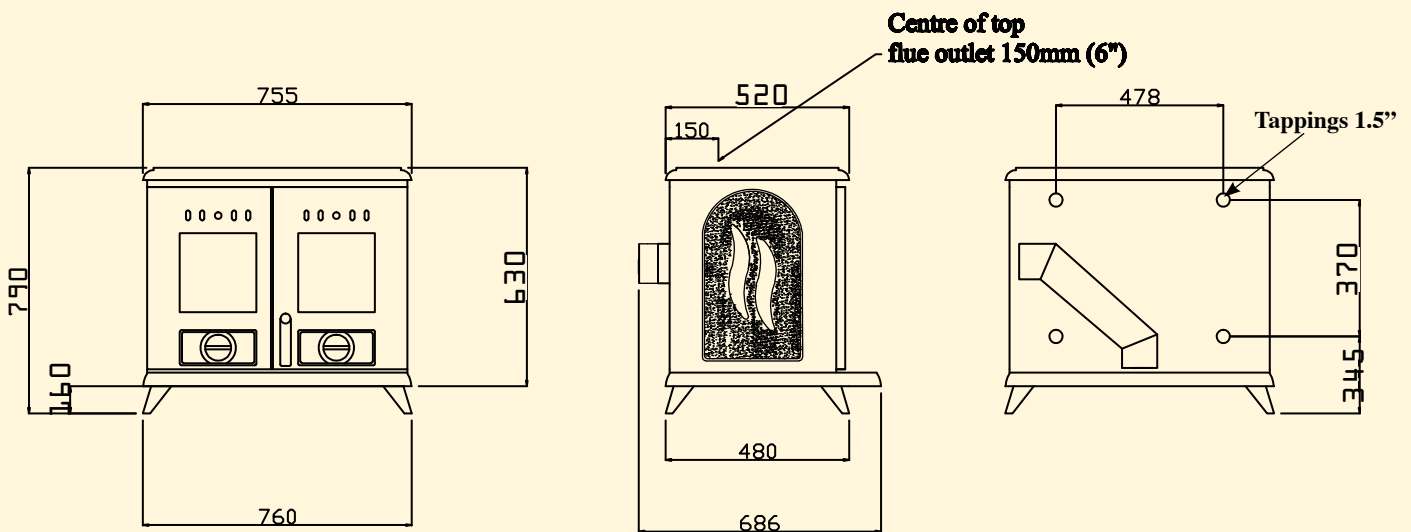

## Guarantee Information

- 2 years on bricks and glass
- 3 years on internal castings
- 5 years on external castings

As part of our process of continuous improvement we reserve the right to change dimensions without notice.



# Blacksmith Stoves®

*'A Cast Iron Masterpiece'*

**Stockist Information:**

**Area Sales Managers: Tom Kelly 087-9124666 Tom Frawley 087-2564702**  
**Blacksmith Stoves®, H-TEC Drainage Systems Ltd.**  
Unit 4 C, Six Cross Roads Business Park, Kilbarry, Waterford  
Tel: +353 51 595003 Fax: +353 51 595944  
**[www.blacksmithstoves.ie](http://www.blacksmithstoves.ie)**